

**Installation and Operation Manual  
for  
Six-inches dome P/T**

Please read the operation manual carefully  
before installing and using this unit

## I. Points for Attention

1. Please read the operation manual carefully before installing and operating the product.
2. The product takes power supply of AC24V. The rated input voltage of the camera is marked on the base or other corresponding place.
3. During the course of transportation, storage and installation, the product should be avoided from incorrect operations such as heavy pressing, strong vibration etc., which can cause damage of product as there are sophisticated optical and electronic devices inside the machine.
4. Do not attempt to disassemble the camera. In order to prevent electric shock, do not remove screws or covers. There are no user-serviceable parts inside.

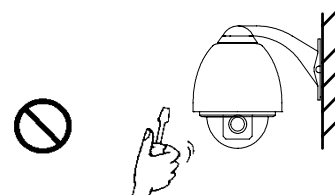

5. Always follow all electrical standards for safety when it is in operation. Adopt the particular power supply which is provided with the unit. RS-485 and video signal should keep enough distance with high voltage equipments and cables when they are in transmission. Precautions for anti-lightning and anti-surfing should be taken if necessary.
6. Do not operate it in case temperature, humidity and power supply are beyond the limited stipulations.
7. Do not let the camera aim at the sun or the object with extreme light whatsoever it is switched on or not. Do not let the camera aim at or monitor bright and standstill object for a long time.
8. Do not use aggressive detergent to clean the main body of the camera. Wipe dirt with dry cloth. If needed, mild detergent can be used suitably.
9. Operate the intelligent speed dome camera with great care to avoid shock or vibration. If it operate incorrectly, the Speed Dome could be damaged
10. Be careful to avoid to crash, Never mount the unit on a ceiling that cannot support its weight.

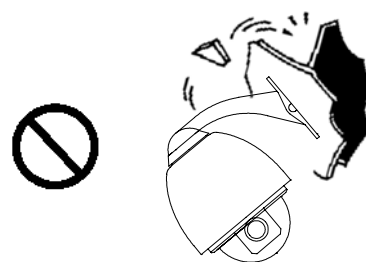

11. If necessary, use a commercial lens cleaning paper to clear the lens windows. Gently wipe the lens window until clean.

## II. Description of Functions

The intelligent dome camera is a hi-tech CCTV product which incorporates high-clarity color camera, panoramic speed-variable PAN/TILT, multifunctional decoder, CPU processor, memory chip into a whole. It can largely reduce connection and installation processes of components in the system, rise up reliability of the system and facilitate installation and maintenance. Therefore it has advantages of beautiful appearance, compact structure and easy operation.

### 1. Integrated Multi-Protocol Decoder

- a. With integrated decoder and multi-protocol, it can integrate 16 kinds of communication protocols in maximum. As its baud rate of communication can be adjusted, it is compatible with many normal systems by easy setup inside the dome camera, so it has stronger versatility.
- b. RS485 serial control: addresses of camera 1-1023.







### 2. Integrated speed-variable PAN/TILT

- a. Turning  $360^{\circ}$  horizontally and continuously with unlimited positions and an adjustable speed from 0.2 - 15rad/s; turning  $0 - 90^{\circ}$  vertically with a speed up to 15 rad/s. Constant speed dome camera PAN/TILT speed: 15rad/s fixed.
- b. Running stably at low speed with super lower noise. Pictures have no shaking.
- c. the location precision up to  $\pm 0.2^{\circ}$ .

### 3. High Intelligent Degree

- a. As much as 64 preset positions can be preset with powerless memory;
- b. The camera can scan horizontally between two points and scan speed can be modified. The positions of linear scan are optional and the dome camera can scan the range larger or smaller than  $180^{\circ}$  between any two points with adjustable speed;
- c. Six sets of programmable tour locus with 16 position each set. The running speed and the detention time are adjustable respectively;
- d. The Integrated Multi-Protocol. Multiple communication protocols are integrated inside the dome camera with selectable baud rate from 2400 bps to 9200 bps.

### 4. Functions of the 18× ZOOM Camera (icons can be displayed on the screen when the option DISPLAY of the camera is ON)

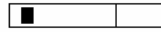
- a. Description of the Focus Control Mode: the user can adjust the focus of the camera manually. When the camera is on near focus, the icon  appears on the screen; when on the nearest state, the icon  appears while on the far focus, the icon  appears.
- b. Description of Backlight Compensation: when the object to be shot is dark and looks dim, the user can open the backlight compensation according to actual need and the icon  appears on the screen.
- c. Description of White Balance: when the image has color distort on the screen, the user can set different modes by orders. There are 6modes for options: ① Indoor Mode  ② Outdoor Mode  ③ Touch Mode  ④ Automatic Trace of White Balance ATW ⑤ Manual WB-MAN ⑥ Automatic Mode.
- d. Description of ZOOM Control: user can “pull near” or “push far” the lens according to actual conditions, and the symbol  $^w$    $^T$  appears on the screen in which the front part means optical multiplication while the rear part means digital multiplication.
- e. Description of Electronic Shutter: it is fixed on 1/50 sec after initialization when the camera is switched on, and the figure 50 appears on the screen.
- f. Setup of Image Effect: the camera works on OFF state under normal condition and no image effect symbol appears on the screen. When “B&W” appears on the screen, it means the camera is on black and white state.
- g. AE Mode: setup of Manual/Automatic.

- h. **Zero Illuminance:** it is used only when the external brightness is extremely low. Normally the camera works on the automatic state. In case the external brightness is lower than 1Lux, the camera can be switch to the Zero Illuminance state automatically and icon  appears on the screen. You can also set the Zero Illuminance state manually.

### III. Setup of the Dome Camera

#### 1. Connection of the System

##### 1) The Systematic Drawing of the Dome Camera

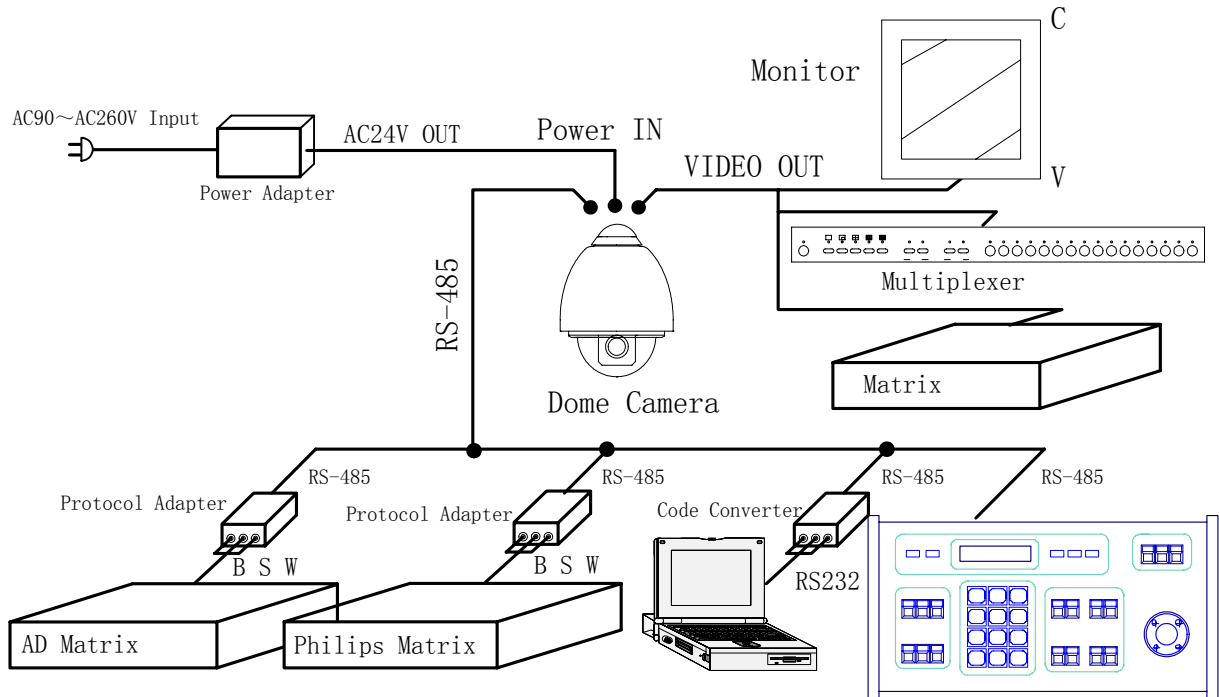

Figure 1

##### 2) Address / Protocol Coding Switch Drawing

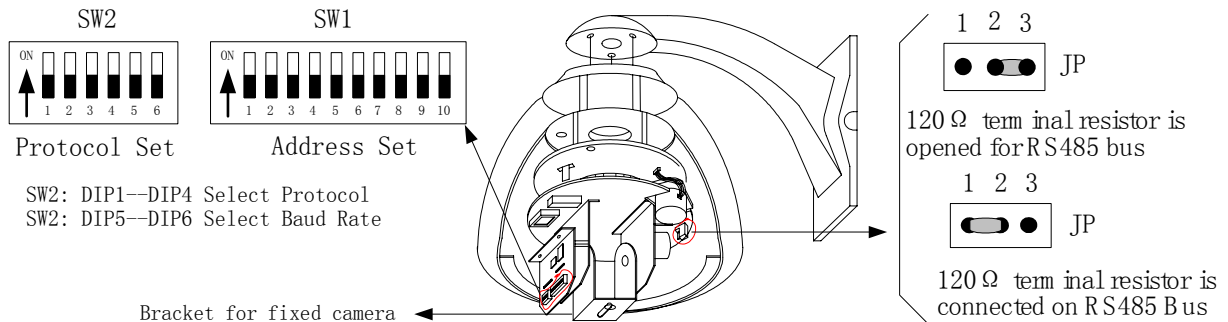

Figure 2

**2. Setup of Coding Switch of Dome Camera.** As shown in Figure 2, SW1 is used to set address of the dome camera from 1 – 1023. The ID-CODE from DIP-10 to DIP-1 are equivalent to a 10-bit binary digit. DIP-10 is MSB while DIP-1 is LSB. The state “ON” of each bit means 1 while “OFF” means 0. Following table shows states of coding switches of some addresses.

Dome Address	ID-CODE Status									
	DIP-1	DIP-2	DIP-3	DIP-4	DIP-5	DIP-6	DIP-7	DIP-8	DIP-9	DIP-10
1	ON	OFF	OFF	OFF	OFF	OFF	OFF	OFF	OFF	OFF
2	OFF	ON	OFF	OFF	OFF	OFF	OFF	OFF	OFF	OFF

## Operation Manual for Intelligent Speed Dome Camera

3	ON	ON	OFF	OFF	OFF	OFF	OFF	OFF	OFF	OFF
4	OFF	OFF	ON	OFF	OFF	OFF	OFF	OFF	OFF	OFF
5	ON	OFF	ON	OFF	OFF	OFF	OFF	OFF	OFF	OFF
6	OFF	ON	ON	OFF	OFF	OFF	OFF	OFF	OFF	OFF
7	ON	ON	ON	OFF	OFF	OFF	OFF	OFF	OFF	OFF
8	OFF	OFF	OFF	ON	OFF	OFF	OFF	OFF	OFF	OFF
9	ON	OFF	OFF	ON	OFF	OFF	OFF	OFF	OFF	OFF
10	OFF	ON	OFF	ON	OFF	OFF	OFF	OFF	OFF	OFF
11	ON	ON	OFF	ON	OFF	OFF	OFF	OFF	OFF	OFF
12	OFF	OFF	ON	ON	OFF	OFF	OFF	OFF	OFF	OFF
13	ON	OFF	ON	ON	OFF	OFF	OFF	OFF	OFF	OFF
14	OFF	ON	ON	ON	OFF	OFF	OFF	OFF	OFF	OFF
15	ON	ON	ON	ON	OFF	OFF	OFF	OFF	OFF	OFF
16	OFF	OFF	OFF	OFF	ON	OFF	OFF	OFF	OFF	OFF
17	ON	OFF	OFF	OFF	ON	OFF	OFF	OFF	OFF	OFF
18	OFF	ON	OFF	OFF	ON	OFF	OFF	OFF	OFF	OFF
...	...	...	...	...	...	...	...	...	...	...
1023	ON	ON	ON	ON	ON	ON	ON	ON	ON	ON

Table 1

For Example:

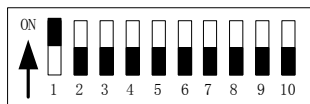

Speed Dome Address=1

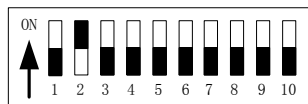

Speed Dome Address=2

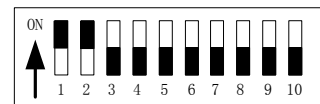

Speed Dome Address=3

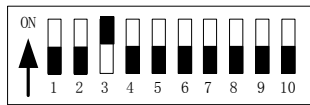

Speed Dome Address=4

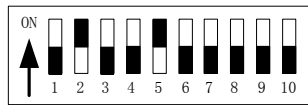

Speed Dome Address=18



Speed Dome Address=1023

- 3. Setup of the Protocol and the Default Baud Rate.** As shown in Figure 2, SW2 is used to set the protocol of communication and the baud rate used by the dome camera. DIP-4 to DIP-1 of SW2 is used to select protocols and 16 different protocols can be selected in maximum. Following table shows states of coding switches of protocols selected by the dome camera in which ● means the protocol has been integrated while ○ means the protocol is temporarily vacant.

Type of Protocols	Selection of Protocols				Normal Baud Rate		Integrated Protocol
	DIP-1	DIP-2	DIP-3	DIP-4	DIP-5	DIP-6	
Minking A01	OFF	OFF	OFF	OFF	ON	OFF	●
Minking B01	ON	OFF	OFF	OFF	OFF	ON	●
Santachi	OFF	ON	OFF	OFF	OFF	ON	●
PELCO-D	ON	ON	OFF	OFF	OFF	OFF	●
PELCO-P/4800	OFF	OFF	ON	OFF	ON	OFF	●
PELCO-P/9600					OFF	ON	
PANASONIC	ON	OFF	ON	OFF	OFF	ON	○
Longcomity	OFF	ON	ON	OFF	OFF	ON	●
HUNDA600	ON	ON	ON	OFF	OFF	ON	●
LILIN	OFF	OFF	OFF	ON	ON	OFF	○
VICON	ON	OFF	OFF	ON	ON	OFF	○
MOLYNX	OFF	ON	OFF	ON	OFF	ON	○
KALATEL	ON	ON	OFF	ON	ON	OFF	○
VCL	OFF	OFF	ON	ON	OFF	ON	○
DAIWA	ON	OFF	ON	ON	OFF	ON	○

## Operation Manual for Intelligent Speed Dome Camera

ALEC	OFF	ON	ON	ON	OFF	ON	○
Utralk	ON	ON	ON	ON	OFF	ON	○

Table 2

Some protocols and the states of the coding switches of normal baud rate of these protocols are shown as follows:

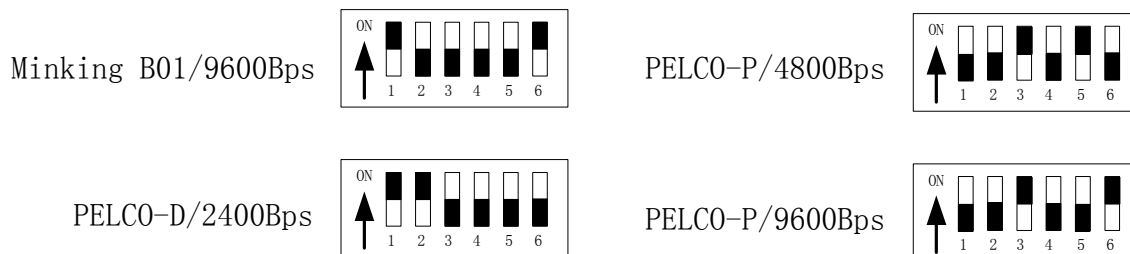

- 4. Setup of the Baud Rate of Communication.** As shown in Figure 2, SW2 is used to set the protocol of communication and the baud rate used by the dome camera. DIP-6 and DIP-5 of SW2 are used to select the baud rate of communication and 4 different baud rates can be selected in maximum. If the controller adopts non-standard baud rate, you can adjust it to be identical with that of the controller as per the following table.

Baud Rate of Communication	DIP-1	DIP-2	DIP-3	DIP-4	Setup of Baud Rate	
					DIP-5	DIP-6
2400bps					OFF	OFF
4800bps					ON	OFF
9600bps					OFF	ON
19200bps					ON	ON

- 5. Selection of the Terminal Resistor of the Dome Camera.** As shown in Figure 2, JP is the select switch of the 120 Ω terminal resistor on the bus RS485, on which only one terminal resistor of the dome camera at the farthest end can be connected, while the terminal resistors of other devices should be opened.
- 6. Special function control.** Some special protocol such as “Santachi”, “PELCO-D” and “PELCO-P” without the command of control some especial functions, in order to use the special functions of dome, so we changed the command of calling/setting NO.51 preset to NO.64 preset to control them.

N	Object of control	Keyboard control	
		Call the N position	Preset the N position
51	Auto scan	Auto scan (low speed)	Auto cruise
52		Auto scan (middle speed)	Set the start point of scan
53		Auto scan (high speed)	Set the end point of scan
54	Camera power	Power on	Power off
55	Back light *	On	Off
56	ICR shor	On	Off
57	OSD (Some cameras have it's own menu, to open/close the menu by the command “turn on the OSD”, and use the command “turn off the OSD” to open/close the OSD)	On	Off
58	Digital Zoom	On	Off
59	FOCUS	Auto	Manual
60	IRIS	Auto	Manual
61	White Balance Mode	Auto	Manual

62		Indoor	Outdoor
63		ATW	One Push WB
64			

## IV. The Installation of the System

### 1. The style of the Installation

#### 1) Dimension of the Product

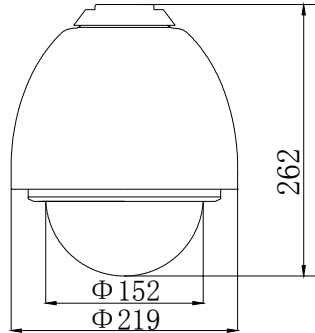

Figure 3

#### 2) The Style of Installation

##### a) Wall Installation

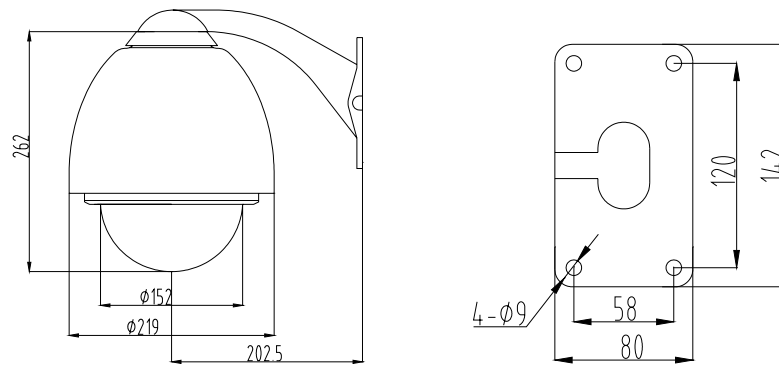

Figure 4

##### b) In-Ceiling Installation

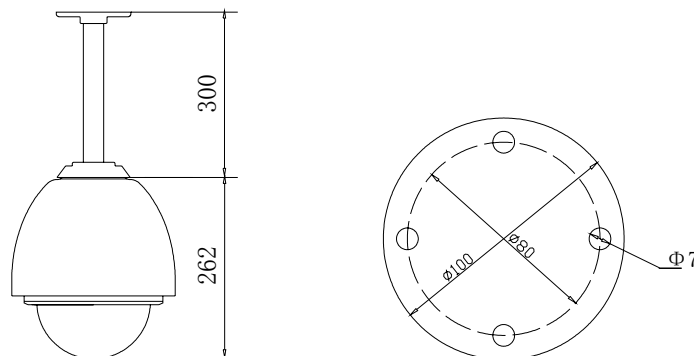

Figure 5

### 2. Steps of Installation (taking wall-mounting as example)

1. Unpacking the carton and carefully take out the dome camera and its attachments.
2. Rotate the vitreous cover counterclockwise and take out it. (see Figure 6) Note: It can be

ignored the steps 2,3,4,5 while the protocol and address are matching with the controller.

3. Take out the black liner. (Figure 7)
4. Based on the ID-CODE shown as Figure 2, set up the protocol used by the camera and the baud rate as per the state according to Table 1. Check the address of the camera to see if it is matched with that you need. If not, set the address of the dome camera at corresponding position as per Table 1.

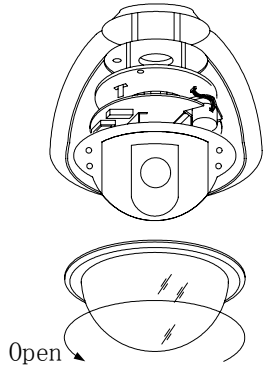

Figure 6

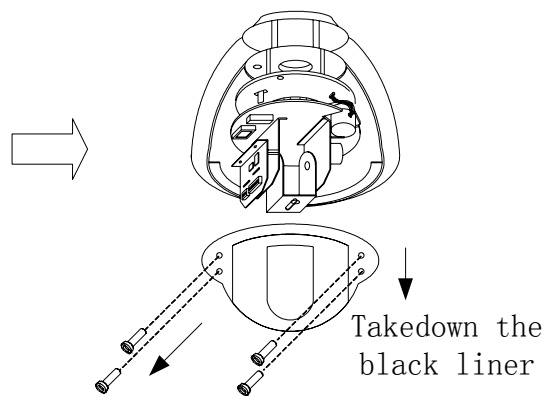

Figure 7

5. Fix the black liner (see Figure 8).

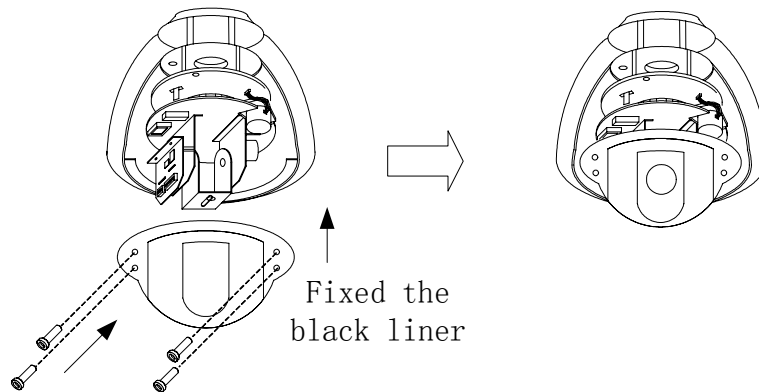

Figure 8

6. Take out the cover of the wall-mounting bracket (see Figure 9).
7. Fix the bracket on the wall (see Figure 10).
8. Drill the system control wires through the bracket (see Figure 11).

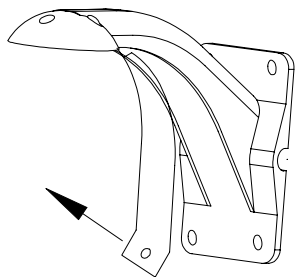

Figure 9

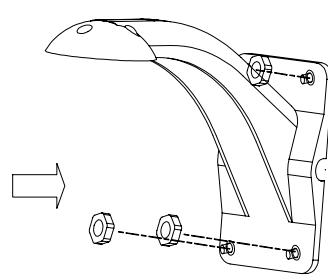

Figure 10

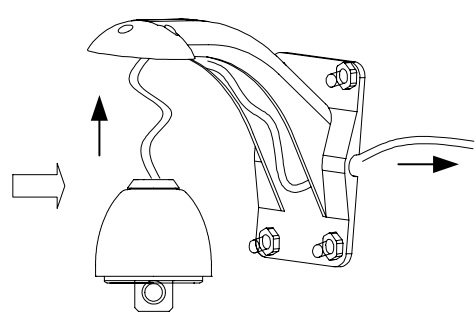

Figure 11

9. Install the aluminum alloy ball on the bracket (Figure 12).
10. Rotate the vitreous cover clockwise and mount it (Figure 13).

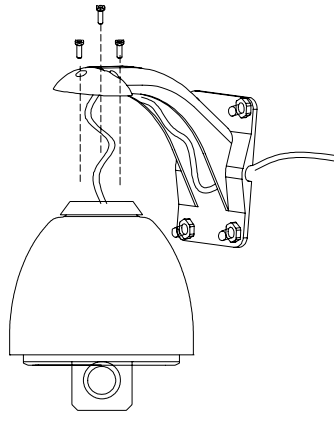

Figure 12

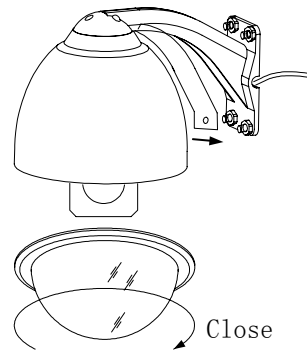

Figure 13

11. Connect the control wires of the system as per Figure 14.

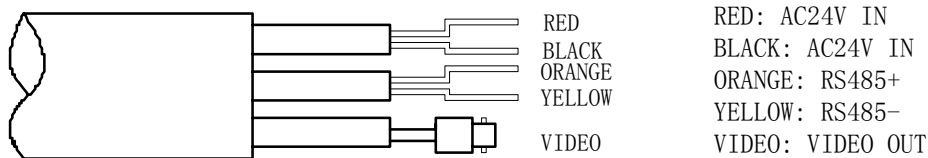

Figure 14

**3. To ensure a smooth and successful installation, you must:**

1. **Have electrical work comply with latest national electrical code, national fire code, and all applicable local codes and ordinances.**
2. **Coordinate work with other trades to avoid interference.**
3. **Verify existing site conditions and coordinate with owner's representative and appropriate utilities as required.**
4. **Obtain copies of all related plans, specifications, shop drawings and addenda to schedule and coordinate related work**
5. **Thoroughly review the project to ensure that all work meets or exceeds the above requirements. Bring alleged discrepancies to the attention of the CCTV Project Coordinator.**

**V. Technical data table**

<b>spec</b>	Image inductor	1/4" color CCD
	pixels	752H×582V (440000pixels) PAL
	in-phase system	in-phase inside
	Video out	1.0Vp-p/75 Ω
	White balance	Auto/manual
	Power supply	AC24V ± 10% 1.25A
	Power consumption	30VA (including the pan/heater devicer)
	weight	4Kg
	Installation	Wall mounting
	Opposite humidity	10-75%
	Environment temp	0°C~40°C

## Operation Manual for Intelligent Speed Dome Camera

<b>Camera function</b>	Scan system	15.625KHz(H) 50Hz(V)
	horizontal	480 horizontal
	Signal-to-Noise	> 48db
	shutter	1/3~1/10000sec
	Sensitivity	0.01~1Lux(F1.6)
<b>Lens parameter</b>	Zoom rate	18x optical 12x digital
	iris	Auto / manual
	focus	Auto / manual
<b>Dome Function</b>	Pan speed	0~15° /s (Fixed 15rad/s for constant dome)
	Tilt speed	0~15° /s (Fixed 15rad/s for constant dome)
	Preset	64presets(max)
	Auto cruise	At best 6 cruises

## VI. Troubleshooting

Problem	Probable cause	Solution
On power no action	Power supply fault	Replace
	Bad connection of the power	Make correction
	Transformer damaged	Replace
On power cannot self-check have image but have motor noise	Mechanical failure	Repair
	Camera incline	Reinstall
	Power supply not enough	Replace
Self-check ok, but have no image	Video signal fault	Reinstall
	Bad connection of the video	Press to full connect
	Camera damaged	Replace
Self-check ok but cannot control	RS485 Bus bad connection	Check the RS485 connection
	Dome id setting is wrong	Reselect
	Protocol setting is wrong	Reset and on power again
Vague image	Bad connection of the video	Press to full connect
	Power supply not enough	Replace
On power cannot control	Self check error	On power again
	Bad connection of control	Press to full connect
	Bad control of matrix	On power again